



Water recycling in can lines

Every drop counts



Saving a substantial amount



Good news for can lines: The used rinsing water offers great potentials for saving water!

How is that?

- The rinsing water is the biggest water consumer in production lines.
- Compared with other consuming systems such as the pasteuriser and filler, it has very little impact on the water quality.
- The result: The rinsing water can be used at another place without any problems.

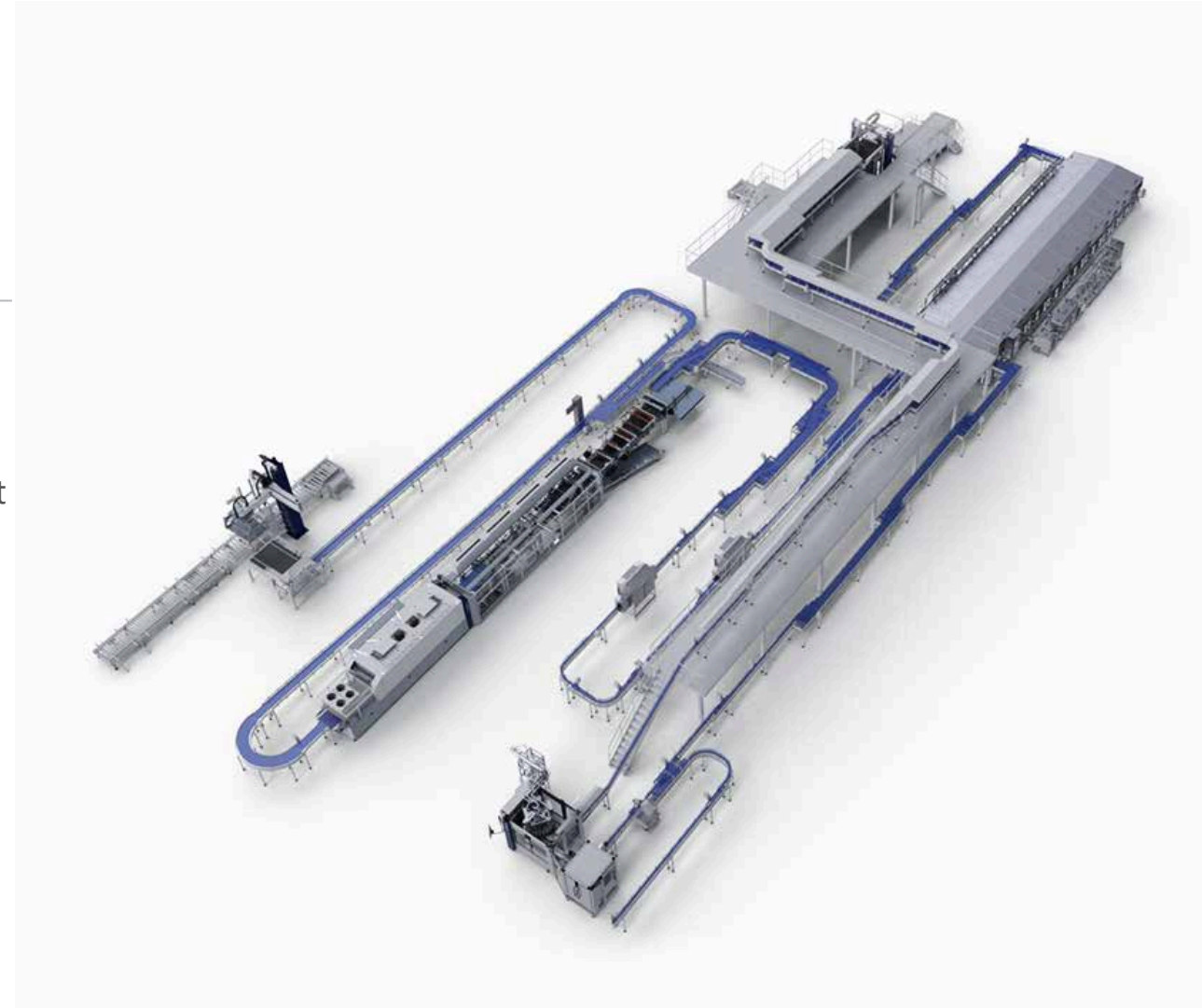

System structure

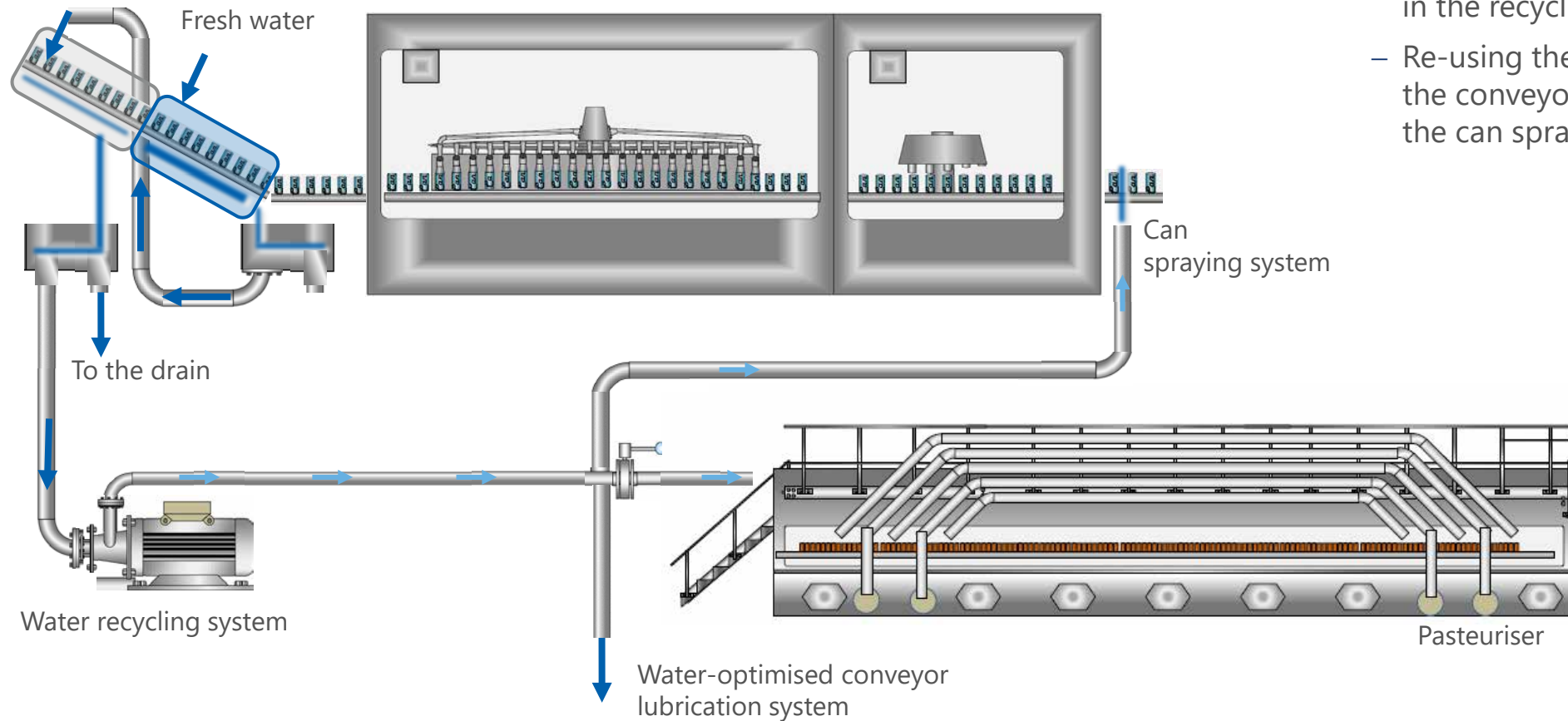

- Collecting and treating the rinsing water in the recycling system
- Re-using the water in the pasteuriser, in the conveyor lubrication system and in the can spraying system

Your benefits in figures



Up to **90 percent** of the used rinsing water can be processed by means of recycling systems.

This way, the fresh water demand of the entire line is reduced by up to **50 percent**.



**SOLUTIONS
BEYOND
TOMORROW**

