

4250

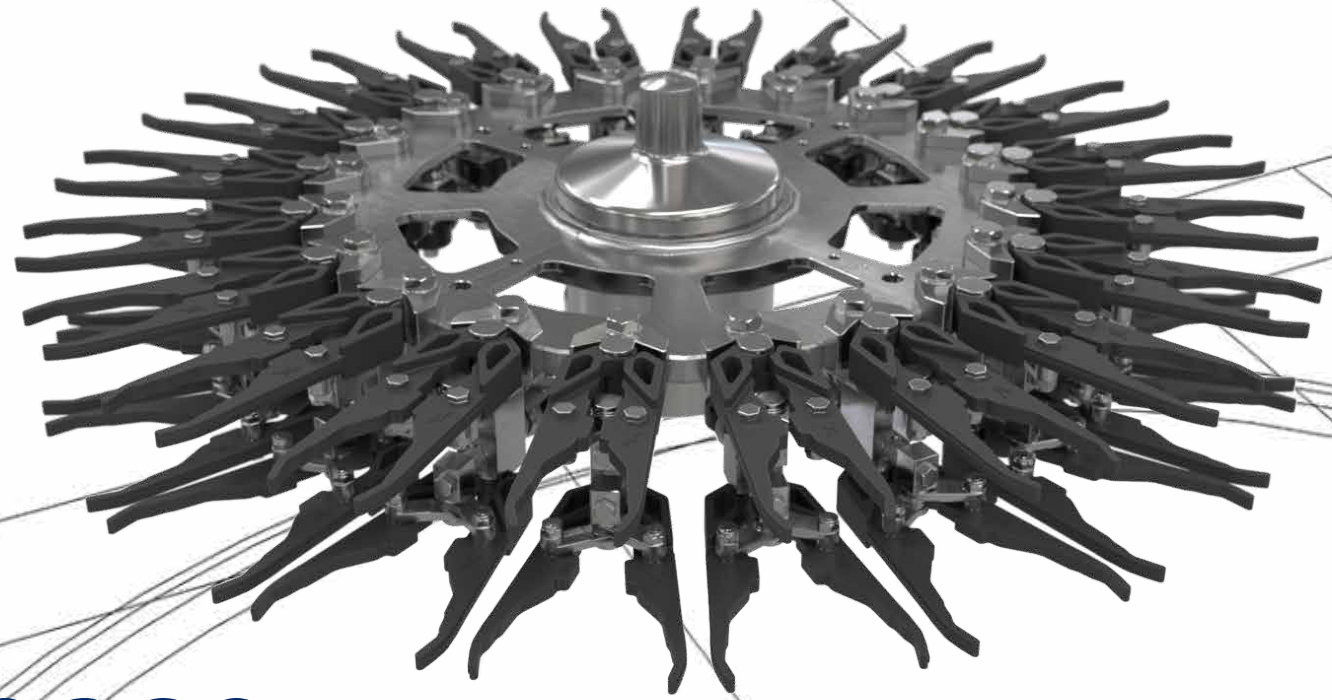

MultiGuide base

Variable size clamping starwheel for a wide range of glass bottle formats



Multi-function starwheel for almost all glass bottle formats



The name already suggests it: Krones MultiGuide Base is a veritable all-rounder. The multifunctional clamping starwheel processes almost all glass bottle formats – and thus combines all the handling parts that are otherwise required for the various container types and sizes. The "one for all" principle saves a great deal of operating effort, time during change-overs and space in the warehouse – a real "win-win-win" situation.

At a glance

- Can be used as transfer and capper starwheel
- Makes manual handling of handling part change-overs redundant
- Processes all common glass bottle formats without the need for manual change-over work
- Output: Up to 66,000 containers per hour (others on request)

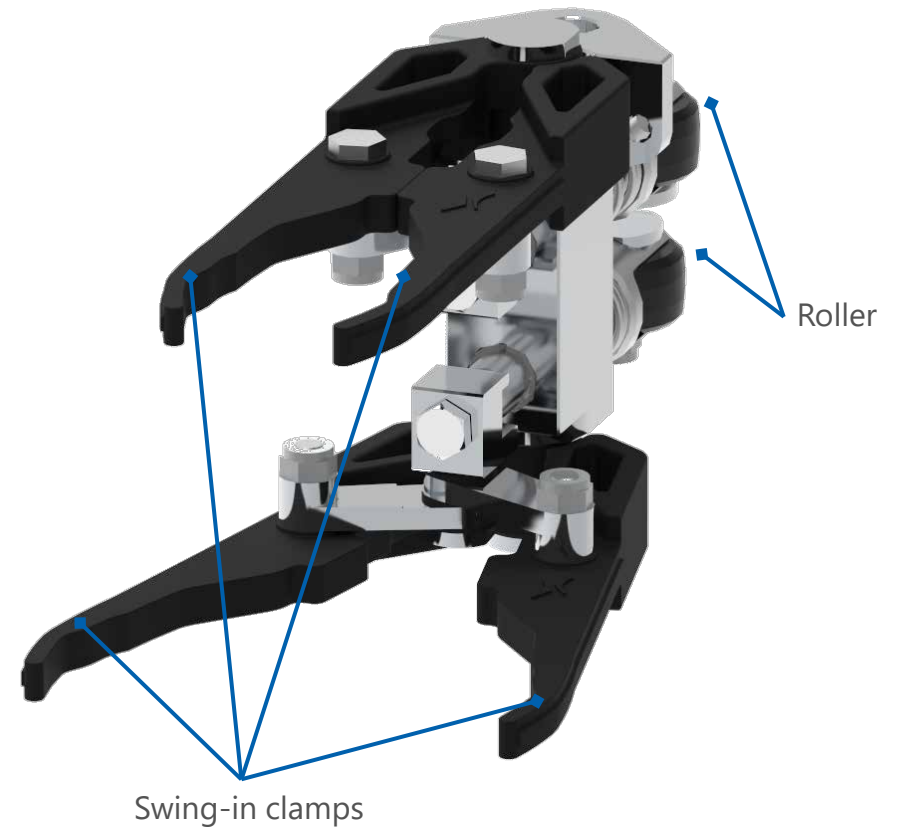

Method of operation

Decoupled gripping for contour bottles with different diameters



The upper and lower clamps can be opened decoupled from each other. This enables gripping of bottles with a different diameter in the neck finish and body area. This means, for example, that even highly contoured bottles can be processed without any problems and without compromising on performance or quality.

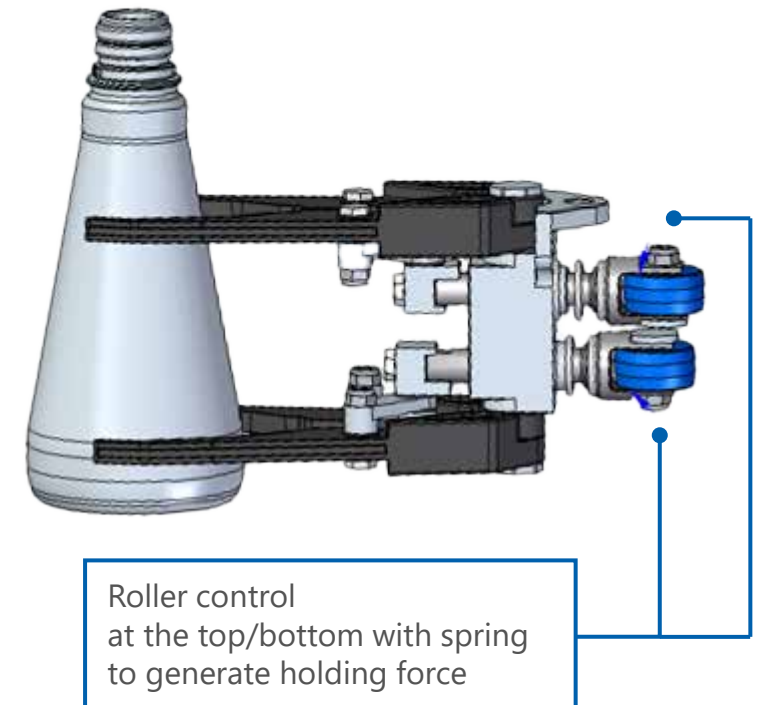
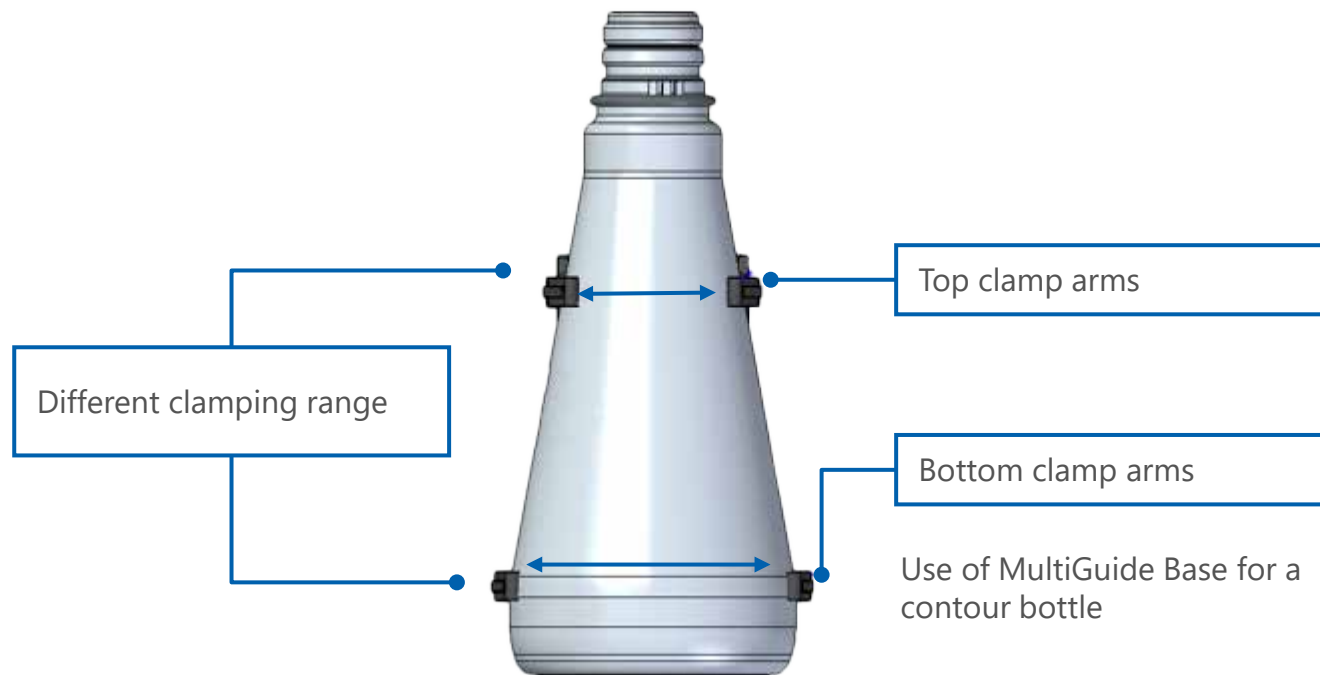

Facts and figures



Krones MultiGuide Base clamping starwheel

Possible diameter ranges of the bottles to be processed	Difference of up to 45 mm possible
Transfer of the bottles	<ul style="list-style-type: none">– One pitch circle for all bottles– Perfect centring at filling valve and capping head– No pressing to the side– Exact transfer
Weight of clamping starwheel	Approx. 26 kg (divisible: 2 x 13 kg)
Change of an individual clamp if broken	Approx. 2 minutes
Weight per clamp unit	1 kg
Position of the spring	<ul style="list-style-type: none">– Outside of the bottle range– As a result: Plus points in terms of hygiene and cleaning

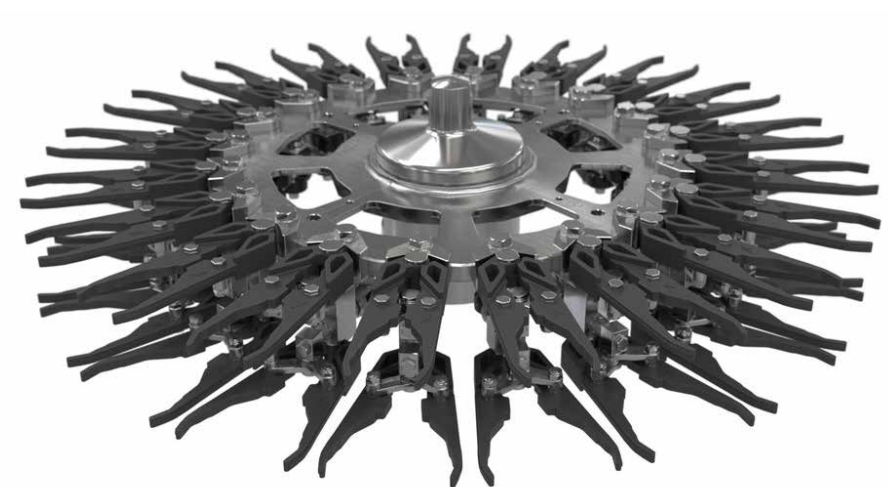

Processing of different glass bottles



Examples of glass bottles which are already processed with MultiGuide Base:

Wine
(0.25 to 1.0 litres)



Beer
incl. swing-stopper bottles
(0.2 to 0.75 litres)



Lemonade
(0.2 to 0.75 litres)



Water
(0.25 to 1.0 litres)



Example of machine dimensioning:



Nine times MultiGuide Base

In detail

- 2 x in Moduljet (infeed and discharge starwheel)
- 1 x as transfer starwheel
- 2 x in Modulfill (infeed and discharge starwheel)
- 2 x in capper (central and discharge starwheel)
- 2 x in second capper (central and discharge starwheel)

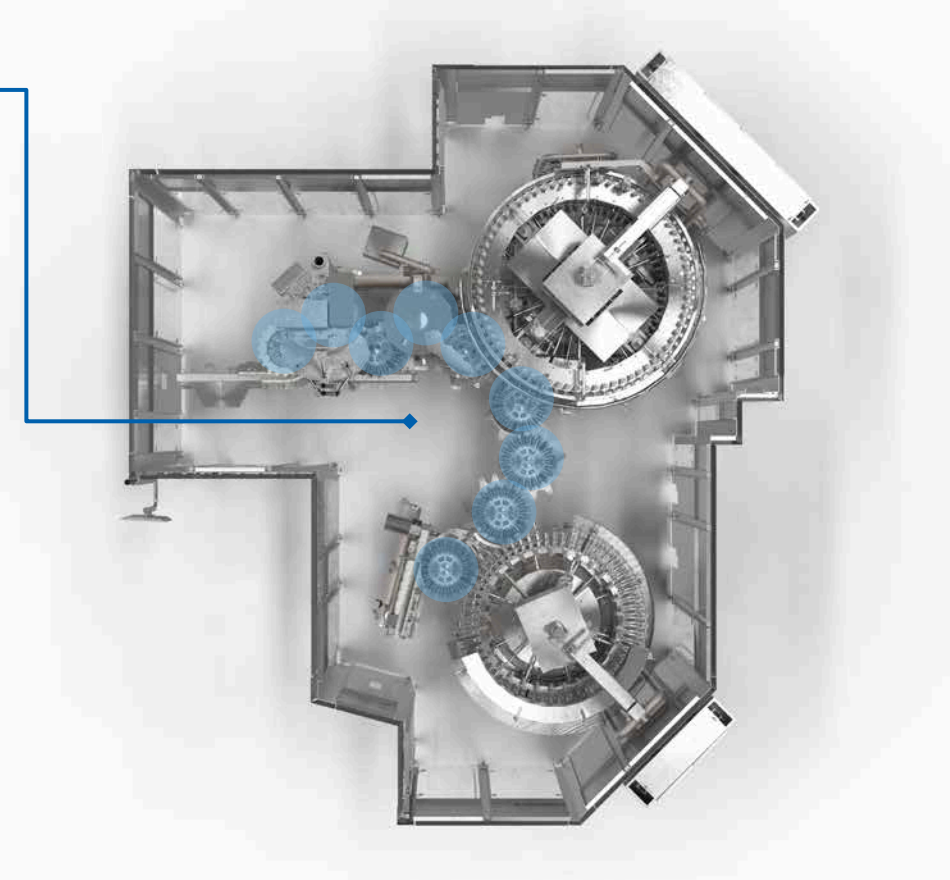
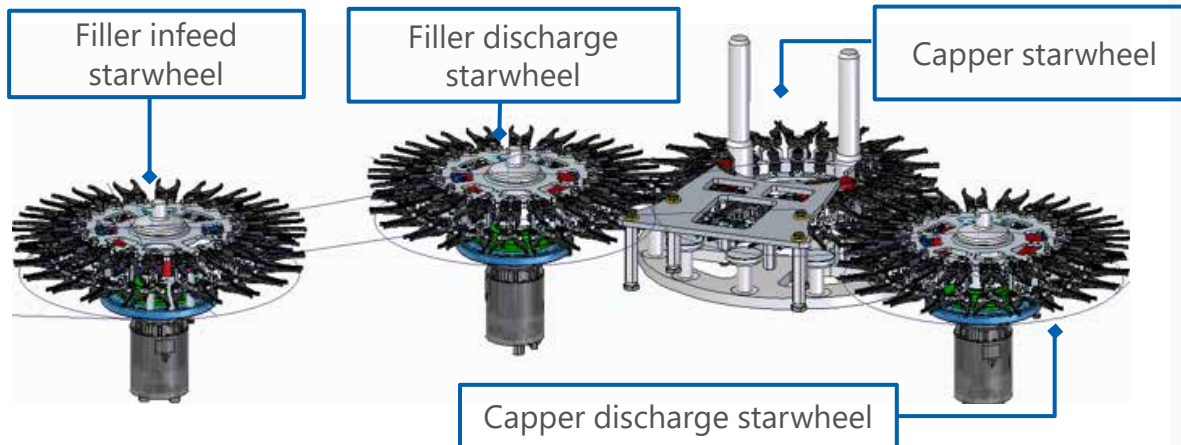

* Layout example: Moduljet rinser with 3,600 mm pitch circle and 90 rinsing units; Modulfill filler with 4,320 mm pitch circle and 108 filling valves; two cappers

Installation and maintenance:



Simple and fast gripper change-over

- The complete clamp unit (pair of gripper clamps at top and bottom) can be removed from the gripper carrier **within approximately one minute.**
- A new clamp unit is applied.
- The removed clamp unit can be maintained separately at rest.

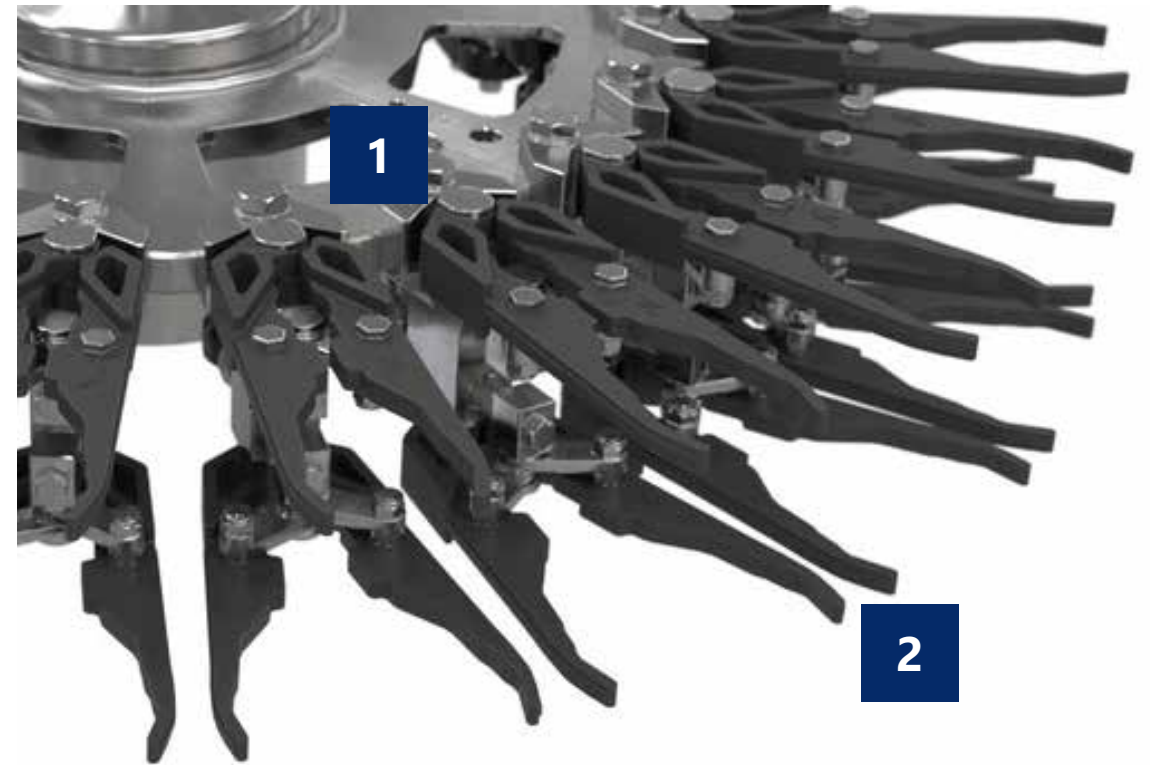

- 1 Release the fastening
- 2 Remove the clamp unit

Benefits to you



Gentle bottle handling

The clamp arms are selectively opened via a spring on the roller and then grip the container in a targeted and secure manner.

Large variety of containers can be processed

The multifunctional clamping starwheel processes the most common glass bottles with diameter differences up to 45 millimetres.

Available also as retrofitting kit

You would like to use the MultiGuide Base also on your existing Krones filler or capper? Simply contact us - and together we will check whether retrofitting the multi-function clamping starwheels is possible in your line.

Double plus points for hygiene

When it comes to hygiene, the MultiGuide Base scores twice: On the one hand, it reduces the risk of contamination, as operator intervention in the filling and capping area is avoided. On the other hand, the clamping starwheels are made in hygienic design and are therefore easily cleaned.

Requesting a new machine

You can easily send a request for a non-binding quotation in our Krones.shop.



Benefits to you



Less change parts and storage space

Since the same clamping starwheel is used for the different container sizes and formats, additional handling parts can be dispensed with and more floor space is available, both next to the machine and in the warehouse.

Change-over times and operator interventions substantially reduced

Since operator intervention is no longer required for format change-overs, manual work and change-over times are reduced enormously - leaving more time for production.

Easy installation and maintenance

If it is necessary to change a clamp, the operator only needs about one minute to do so, and no fine adjustments are required.

Requesting a new machine

You can easily send a request for a non-binding quotation in our [Krones.shop](#).



Everything from a single source



Training courses at the Krones Academy – trained personnel will increase your line efficiency

The multifaceted offer by the Krones Academy ranges from operation, servicing and maintenance courses through to management training. We will gladly also create your individual training programme.

KIC Krones cleaning agents make your machine shine

An immaculate production environment is essential if your product is to shine. KIC Krones provides you with the optimum cleaning agents and disinfectants for each individual production step.

Krones Lifecycle Service – Partner for Performance

It goes without saying that also after the purchase of new machines, Krones takes care of your lines: The Krones LCS experts are always there to help you reaching your goals and turn your wishes into optimal LCS solutions.

**SOLUTIONS
BEYOND
TOMORROW**

