



# Ergomatic

For cold glue labelling



# High flexibility for cold glue labelling



When it comes to decorating containers with cold glue and cut paper labels, the Ergomatic system has been setting the benchmark for many years now. The machine has been designed as rotary machine and is equipped with a precisely operating labelling station. In terms of efficiency, accuracy and speed, the Ergomatic is absolutely unrivalled.

## At a glance

---

- Cold glue labelling on round and specially shaped containers
- Precise container positioning with centring bells and centring plates
- Quick access to the user interface through individual transponders
- Remote maintenance is available as an option



# Method of operation



- 1** An infeed worm spaces the incoming containers to the correct machine pitch.
- 2** The infeed starwheel transfers the containers to the rotating container table. Here they are firmly held between the container plates and the centring bells and centred for the labelling process.
- 3** In each labelling station, a glue roller made of hardened steel applies a very thin layer of glue to the rubberised glue pallets.
- 4** The glued pallets pick up the labels from the label magazine and pass them on to the gripper cylinder. The gripper cylinder positions these labels accurately on the containers as they pass by on the container table.
- 5** Brushes or sponge rollers hold the labels on the container and smooth them down.
- 6** The labelled containers are collected by the discharge starwheel and transferred to the conveyor.

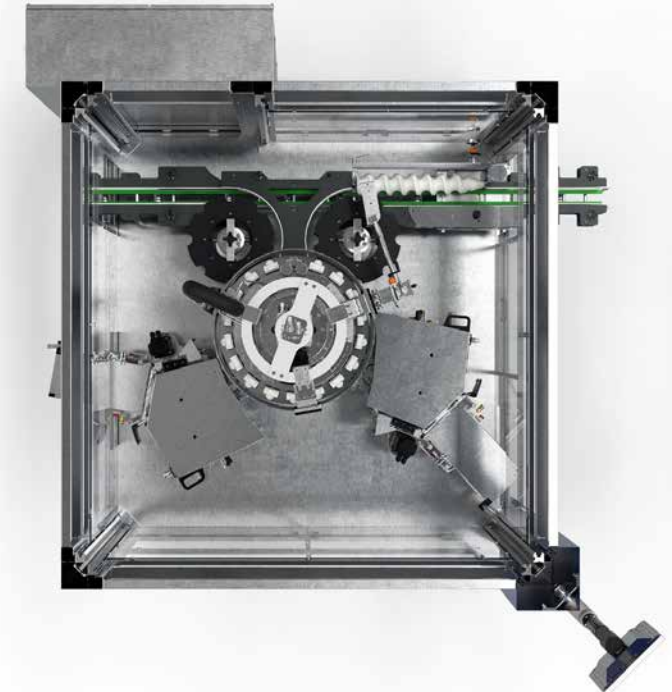

# Ergomatic CL labelling station



## Technical features and benefits

- Output range of 3,000 to 72,000 containers per hour, with only one label applicator, depending on the label width
- The glue pallets have an oscillating movement
  - Low strain on the label through reduced pallet speed during label handling
- Hygienic design with smooth surfaces
  - Quick and easy to clean
- Polygon holders for glue roller, pallets and gripper cylinders
  - High-precision container decoration
- Glue roller bearing with freewheel device
  - Reduced wear on the glue pallets
  - Even glue application on the pallets
  - The glue roller can be removed for cleaning without tools
- Mechanical adjustments with counter
  - Exactly reproducible settings for type change-over

CL: Classic





# Additional equipment

## Automatic magazine loading system



### Method of operation

- Supply of approx. 50,000 labels per labelling station
- For label widths up to 180 millimetres
- Tried-and-tested, functionally reliable unit

### Benefits to you

- The operators can prepare several label magazines in one work step while production is ongoing
- The machine is productive for longer without any need for operator intervention
  - Less work for the operators
  - Modern production system with a high-performance output



# Additional equipment



## Split glue scraper

- The split glue scraper allows two different glue thicknesses to be applied on one glue roller
- The segments of the split glue scraper are each adjusted with a separate micrometer screw with register
- This makes it possible to apply the ideal glue thickness when using different label types and materials

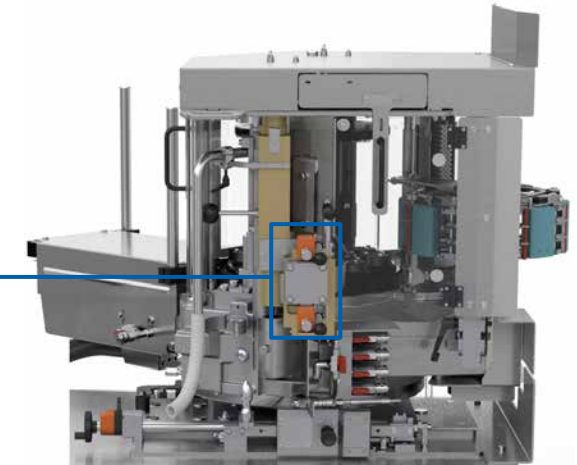

## Multifunctional clamping starwheel

- Available as infeed, discharge, or distribution starwheel
- No curved guides required
- Use of starwheels for several container types with varying diameters
- Can be used as a rejection unit after the label inspector





# System expansion

## Labelling of swing stoppers



### Method of operation

- Alignment of the containers with a camera system
- The swing-stopper labels are pressed on inside the machine with pressing-on units.

### Benefits to you

- The swing-stopper label is pressed on immediately after being transferred to the bottle.
  - High labelling accuracy
- Split glue scraper for different glue film thickness for body and swing-stopper labels
  - Optimum glue application
- The body label is brushed on at the same time as the swing-stopper label is pressed on.
  - Optimum carousel design



# System expansion

## Neck-foil brushing-on unit



### Technical features

- Foil as a premium label and for authenticity protection
- Dedicated folding, smoothing, rolling-on and brushing-on devices
- Available variants:
  1. Smoothly applied foil – refer to the illustration
  2. Neck foil without post-treatment
  3. Foil with material accumulation on the crown
  4. Foil with the top open, with post-treatment
  5. Foil with the top open, without post-treatment

### Benefits to you

- The foils can be precisely centred above the body label and carefully brushed on to the neck or closure area.
  - Consistent labelling results
- Split glue scraper for different glue film thickness for body labels and foil labels
  - Optimum glue application





# System expansion

## Checkmat inspection unit



### Method of operation

Configuration in packages (0, 1, 2, 3) with the following inspection options for the label and print depending on the requirements:

1. Presence
2. Position and slant
3. Correctness using a 2D code
4. Comparison of pattern and logo
5. Flagging labels
6. Bar code: Check for presence and read
7. OCR (Optical Character Recognition): Check for presence and read (e.g. date)

### Benefits to you

- Rejection of faulty containers
- Comprehensive statistics functions and software
- Perfect integration in the main machine
- Relief for the operators
  - Creation of new types for additional graphics with wizard



Compact camera

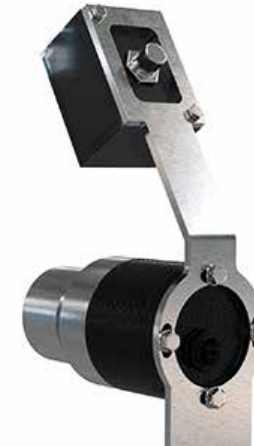

EM camera in packages (0, 1, 2, 3)

# Benefits to you



## User friendliness

The Ergomatic offers easy access and is very user-friendly to operate.

## Flexible application

The Ergomatic can process a wide range of different labels.

## Large output range

The machine covers the full range – from the low output range to the highest.

## High labelling precision

Fixation of containers between the centring bell and the container plate ensures a highly precise container decoration.

## Reduced workload for operators

The optionally available automatic magazine loading system reduces the workload for operators during production.

## Time savings

Only short change-over times needed when changing container or label type.

## Future-proof

It will still be possible to update and convert the Ergomatic system after many years of service.



## Request new machine

You can easily send a request for a non-binding quotation in our [Krones.shop](#).



# Everything from a single source



## KIC Krones adhesives – the all-rounder for a strong grip

Regardless if PET or glass, plastic or paper, labels or packagings – at KIC Krones, you will find your ideal adhesives for a high-quality product presentation.

## KIC Krones cleaning agents make your machine shine

Only if the production environment is immaculate, can your product be brilliant. KIC Krones provides you with the optimum cleaning agents and disinfectants for each individual production step.

## KIC Krones lubricants for each production step

Whether for gears, chains or central lubrication systems – our greases and oils are true all-round talents. They can reach every lubrication point, protect your line and ensure gentle treatment for your products thanks to their food-grade quality.

## Krones Lifecycle Service – Partner for Performance

It goes without saying that also after the purchase of new machines, Krones takes care of your lines: The Krones LCS experts are always there to help you reaching your goals and turn your wishes into optimal LCS solutions.





**SOLUTIONS  
BEYOND  
TOMORROW**

